

VOLUME 01 / **AR DUE** THE KITCHEN

# KYOTO

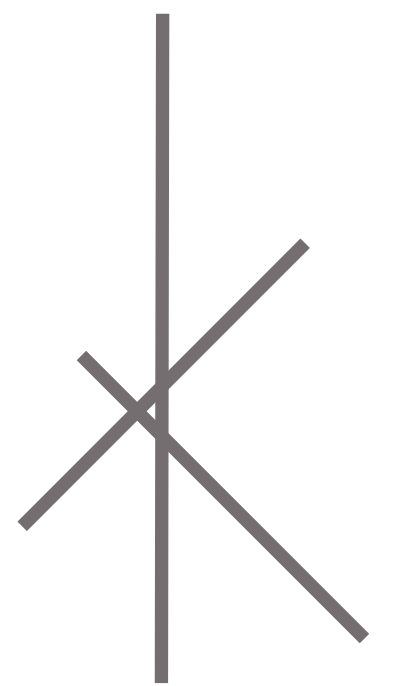





AR-DUE THE KITCHEN

KYOTO

LA COLLEZIONE DI CUCINE KYOTO ESPRIME ATTRAVERSO L'ANTA A TELAIO, L'ESSENZA DI ROVERE E LE GRADAZIONI DI COLORI PASTELLO, LA SUA IDENTITÀ STILISTICA. LE PROPOSTE D'ARREDO SONO SINTESI DI UN'EQUILIBRIO ZEN TRA FORMA E SOSTANZA. GLI AMBIENTI SONO LUMINOSI, GLI SPAZI APERTI ALLA VISIONE, AL RESPIRO PER CHI RITIENE LA CUCINA NON SOLO COME IL CENTRO DELLA CASA, MA IL LUOGO PER ECCELLENZA DELL'INCONTRO DOVE ANCORA CI SI RIUNISCE NELLA SACRALITÀ DI GESTI DI CONVIVIALITÀ E BELLEZZA. NOVE PROGETTI CHE EVIDENZIANO UNA GRANDE VERSATILITÀ E PERSONALIZZAZIONE CHE EMERGE DAI PIANI IN CUI LA MATERIA DISEGNA LE SUPERFICI E GLI SCHIENALI, COSÌ COME IL ROVERE SI ESTENDE A CREARE BOISERIE ATTREZZATE A RIPIANI UNENDO UTILE AL BELLO. KYOTO, LA CUCINA MADE IN ITALY, CHE SA GUARDARE LONTANO.

KYOTO COLLECTION EXPRESSES ITS STYLISTIC IDENTITY THROUGH THE FRAMED DOOR IN ROVERE AND IN THE SHADES OF PASTEL COLORS. THE FURNISHING PROPOSALS ARE SYNTHESIS OF A BALANCE BETWEEN FORM AND SUBSTANCE. THE SPACES ARE BRIGHT, OPEN TO VISION, THEY ARE DESIGNED FOR THOSE WHO CONSIDER THE KITCHEN AS THE CENTER OF THE HOME, THE PLACE OF MEETING, OF BEING TOGETHER, WHERE THE GESTURES OF CONVIVIALITY ARE EXPRESSIONS OF BEAUTY. NINE PROJECTS THAT HIGHLIGHT A GREAT VERSATILITY AND CUSTOMIZATION THAT EMERGES FROM THE WORKTOPS IN WHICH THE MATERIAL DRAWS THE SURFACES AND THE BACKSPLASHES, JUST AS THE ROVERE EXTENDS TO CREATE BOISERIE EQUIPPED WITH SHELVES, COMBINING THE USEFUL WITH THE BEAUTIFUL. KYOTO, THE MADE-IN-ITALY KITCHEN THAT KNOWS HOW TO LOOK FAR AHEAD.

# KYOTO / 01

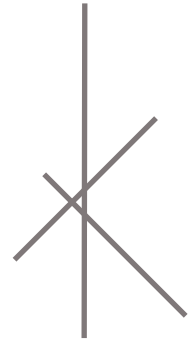

AR-DUE THE KITCHEN



L'ANTA A TELAIO KYOTO, LACCATO OPACO E ROVERE, FA DA CORNICE IN QUESTO PROGETTO LINEARE CON ISOLA CENTRALE. AL TOP UN PARTICOLARE QUARZORESINA PLANET TEMPEL CHE DISEGNA COME IN UNA TELA DEL PITTORE, SEGNI DISTINTIVI DI PERSONALITÀ.

IN THIS LINEAR PROJECT WITH CENTRAL ISLAND, THE KYOTO FRAMED DOOR, LACQUERED AND ROVERE, FRAMES THE WORKTOP IN QUARZORESINA PLANET TEMPEL THAT DRAWS, LIKE IN A PAINTER'S CANVAS, DISTINCTIVE SIGNS OF PERSONALITY.





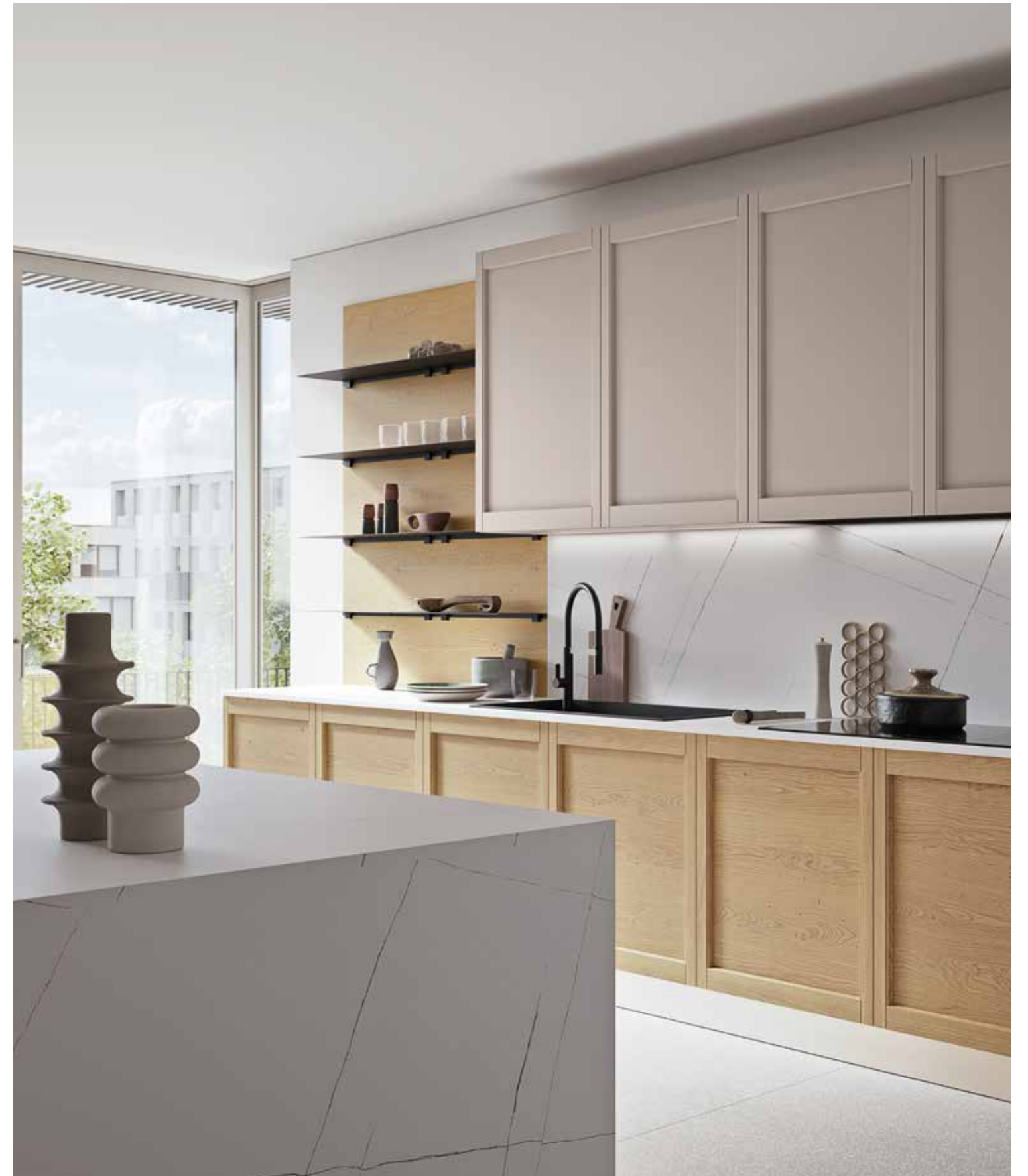



# KYOTO / 01 FINISHES

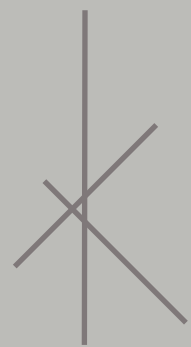

AR-DUE THE KITCHEN



## ANTE / DOORS

01\_\_LACCATO OPACO NEBBIA

02\_\_ROVERE

## PIANI / TOPS

03 \_\_QUARZORESINA PLANET TEMPEL

LA SCELTA DEL MATERIALE E DEL COLORE É DETERMINANTE PER CREARE UN PROGETTO CUCINA COERENTE ED EQUILIBRATO. LE ANTE A TELAIO DI KYOTO PERSONALIZZANO BASI E PENSILI MENTRE IL QUARZORESINA RIVESTE AL TOP E SCHIENALI LE SUPERFICI DEDICATE ALL'OPERATIVITÀ.

\_\_\_\_\_THE CHOICE OF MATERIAL AND COLOR IS DECISIVE IN CREATING A COHERENT AND BALANCED KITCHEN DESIGN. KYOTO FRAMED DOORS CUSTOMIZE BASE AND WALL UNITS WHILE THE QUARZORESINA COVERS TOPS AND BACKSPLASHES.

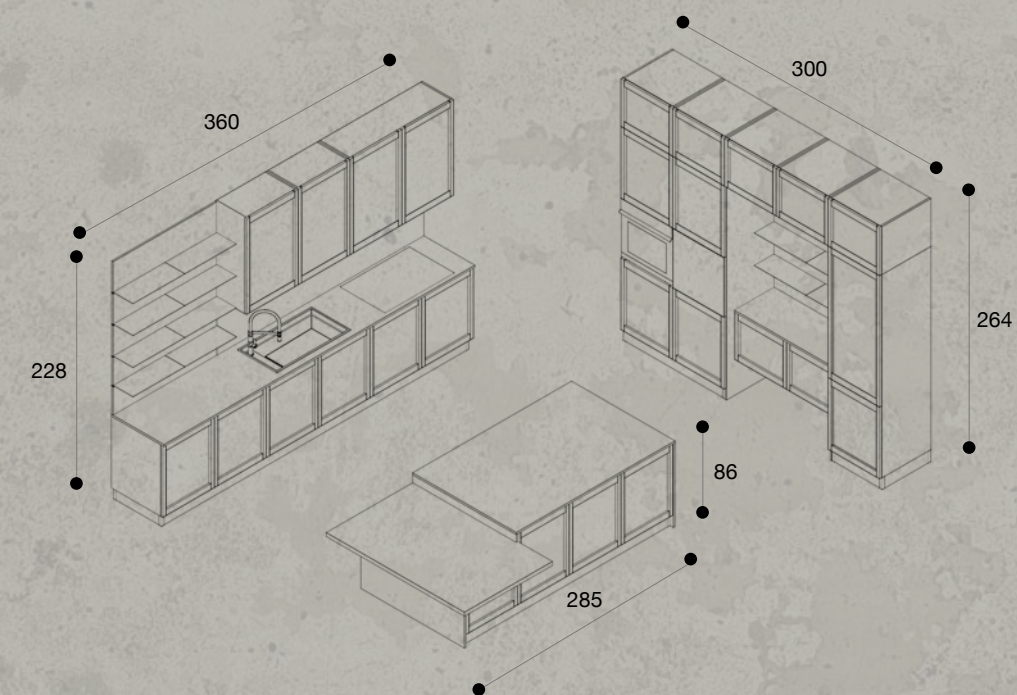

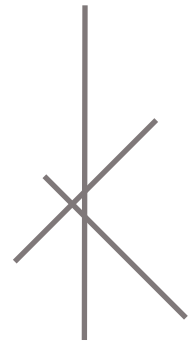

KYOTO SI VESTE DI UN COLORE MOLTO FEMMINILE CAMBIANDO RADICALMENTE LA SUA ESSENZA, SI PERCEPISCE E VIBRA L'INTENSITÀ DELLA VITA CHE CHIAMA ALLA CONDIVISIONE E ALL'ACCOGLIENZA DELL'OSPITE E TI SENTI A CASA.

KYOTO DRESSES ITSELF IN AN INTENSE COLOUR, RADICALLY CHANGING ITS ESSENCE, YOU CAN FEEL THE INTENSITY OF LIFE THAT CALLS FOR SHARING AND WELCOMING THE GUEST.

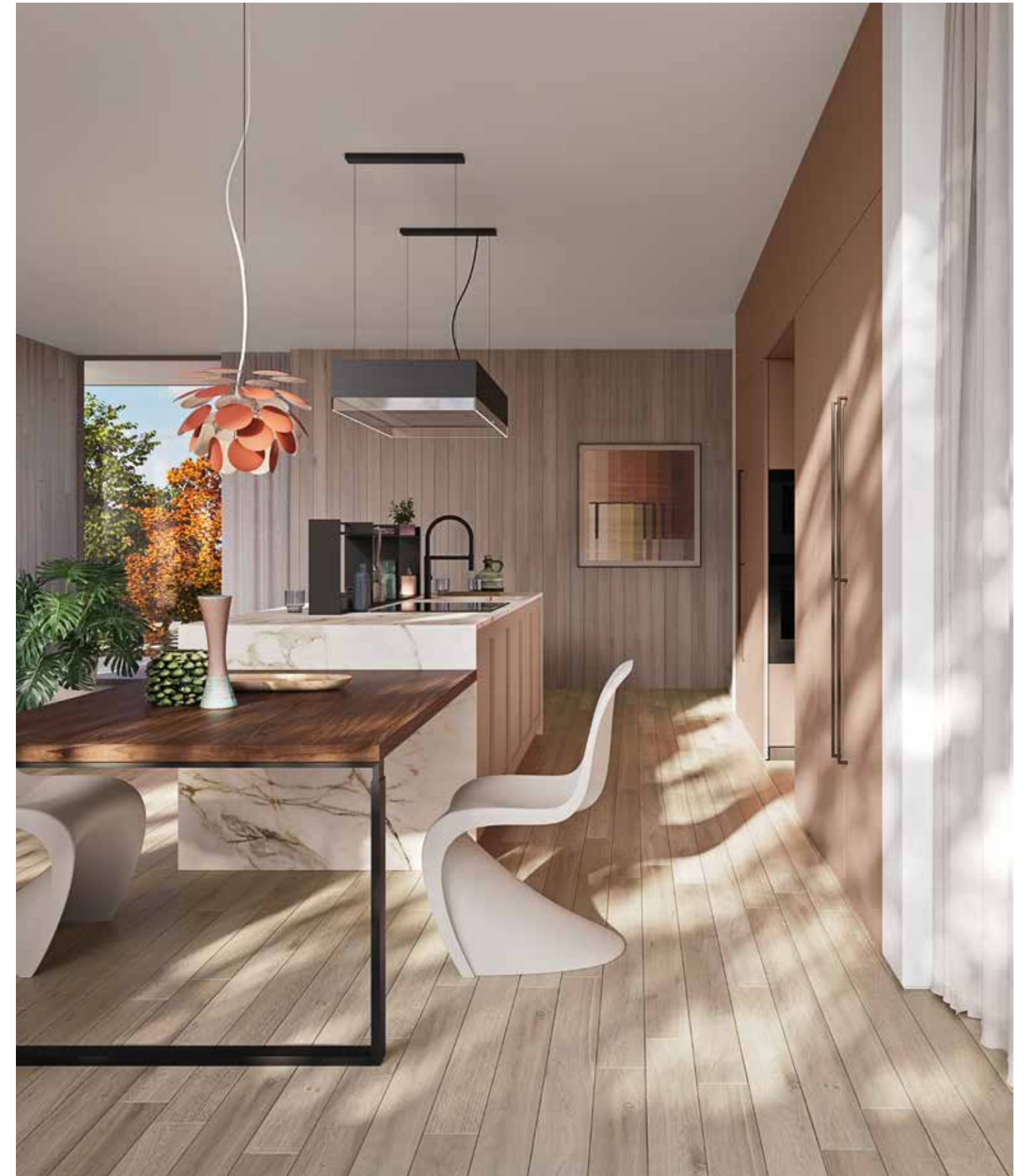





LA CERAMICA CALACATTA GOLDEN OPACO AVVOLGE L'ISOLA IN CONTRASTO CROMATICO NETTO CON IL TAVOLO IN NOCE ITALIA "SCURO", UNA VERSIONE CHE ACCENTUA LA PERSONALITÀ DI UN'ARREDO CHE INCONTRA LO SPIRITO INDOMITO DI CHI LA SCEGLIE.

THE WORKTOP IN CERAMICA CALACATTA GOLDEN OPACO WRAPS THE ISLAND, IN A CLEAR COLOUR CONTRAST WITH THE TABLE IN NOCE ITALIA. A VERSION THAT ACCENTUATES THE PERSONALITY OF A FURNITURE THAT MEETS THE UNBOWED SPIRIT OF THOSE WHO CHOOSE IT.



# KYOTO / 02 FINISHES

AR-DUE THE KITCHEN

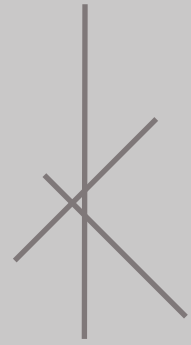

**ANTE / DOORS**

- 01\_\_LACCATO OPACO ROSA JADORE
- 02\_\_LACCATO OPACO Q01 ROSA JADORE

**PIANI / TOPS**

- 03\_\_CERAMICA CALACATTA GOLDEN OPACO

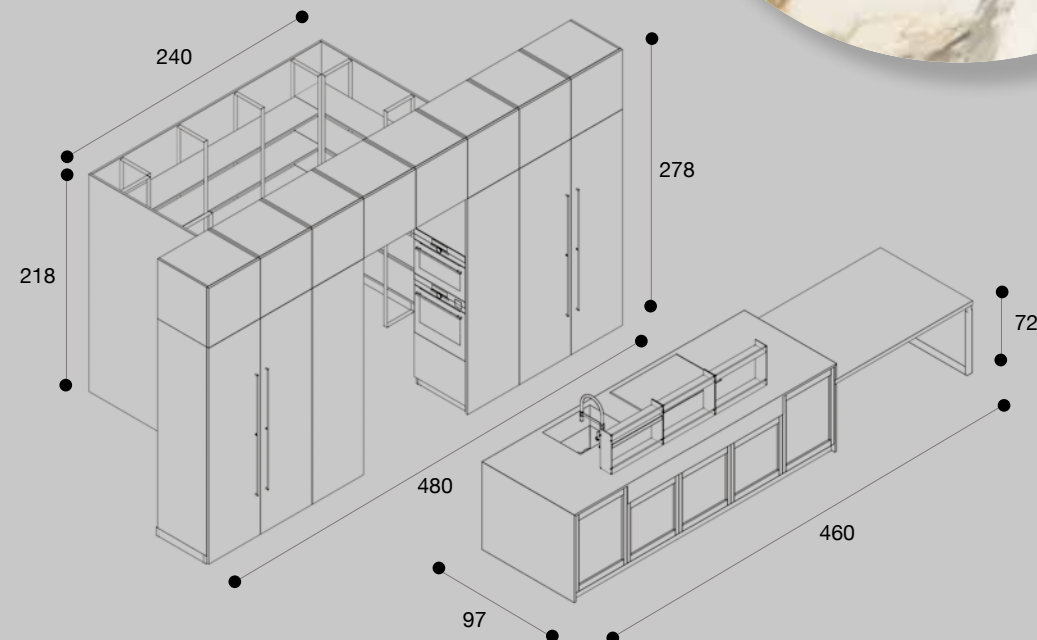

ANTE LISCE ALLE COLONNE, A TELAIO NELLE BASI SI COMBINANO CON MAESTRIA IN UN COLORE PARTICOLARMENTE FEMMINILE, LA CERAMICA CALACATTA GOLDEN OPACO ESALTA I PIANI DELL'ISOLA CON LE SUE VENATURE FIGLIE DEL TEMPO. \_\_\_\_\_AN INTENSE COLOR ENHANCES THE SKILFUL COMBINATION BETWEEN THE TALL UNITS WITH SMOOTH DOORS AND THE FRAMED DOORS OF THE BASE UNITS. THE CALACATTA GOLDEN OPACO IN CERAMICA ENRICHES THE ISLAND TOP WITH ITS VEINING.



# KYOTO / 03

AR-DUE THE KITCHEN

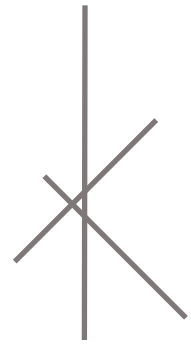

KYOTO OFFRE "OPENSPEACE", APERTI ALLA VISUALE, NEI QUALI ALL'INTERNO GOVERNA ORDINE E ORGANIZZAZIONE, COSÌ IN QUESTO MIX DI ELEMENTI IL PIATTO CHE PREPARETE AVRÀ UN SAPORE PIÙ INTENSO, QUELLO DI SCELTE CONSAPEVOLI CHE RICONOSCONO NELLA QUALITÀ DEGLI INGREDIENTI UN VALORE IRRINUNCIABILE.

KYOTO IS SUITABLE FOR THE CREATION OF OPEN-PLAN LAYOUTS IN WHICH THE SENSE OF ORDER AND ORGANIZATION STANDS OUT. A MIX OF ELEMENTS DETERMINED BY CONSCIOUS CHOICES, SUCH AS THE FOOD PREPARATION WHERE THE QUALITY OF THE INGREDIENTS BECOMES AN ESSENTIAL VALUE.







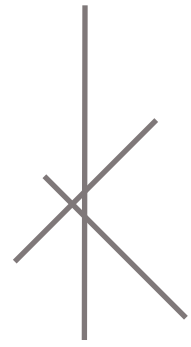

LA VERSATILITÀ E LA RICCHEZZA MODULARE DI KYOTO, CONSENTE DI SUPERARE IL CONCETTO DI PARETI CHE DIVIDONO TRASFORMANDOLE IN PARETI CHE COLLEGANO, SPAZI E AMBITI DIFFERENTI. QUI GLI ELEMENTI A GIORNO SI APRONO AL LIVING CON LIBRERIE CONTEMPORANEE IN ROVERE.

THE VERSATILITY AND MODULAR RICHNESS OF KYOTO, MAKE IT POSSIBLE TO OVERCOME THE CONCEPT OF WALLS THAT DIVIDE BY TRANSFORMING THEM INTO WALLS THAT CONNECT, DIFFERENT SPACES AND AREAS. HERE THE OPEN ELEMENTS OPEN TO THE LIVING ROOM WITH CONTEMPORARY BOOKCASES IN ROVERE.



# KYOTO / 03 FINISHES

AR-DUE THE KITCHEN

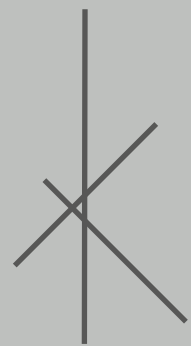

## ANTE / DOORS

01\_\_LACCATO OPACO BIANCO GHIACCIO

02\_\_LACCATO OPACO VERDE CELADON

## PIANI / TOPS

03\_\_CERAMICA ZAHA STONE SILK

UNA COMPOSIZIONE CHE SI RACCONTA ATTRAVERSO SPAZI APERTI, COORDINATI DALLA NATURALITÀ DEI FRONTALI TELAIO IN LACCATO OPACO VERDE CELADON E BIANCO GHIACCIO. IL ROVERE DIVIENE PROTAGONISTA DI ELEMENTI A GIORNO SU BOISERIE A RIPIANI E LIBRERIE, COLLEGANDO LA CUCINA ALL'AREA LIVING. \_\_\_\_\_ A COMPOSITION THAT TELLS ITS STORY THROUGH OPEN SPACES, COORDINATED BY THE NATURALNESS OF THE FRAMED FRONTS IN VERDE CELADON AND BIANCO GHIACCIO LACQUER. THE ROVERE FINISH BECOMES THE PROTAGONIST OF OPEN ELEMENTS, BOISERIE AND BOOKCASES, CONNECTING THE KITCHEN TO THE LIVING AREA.

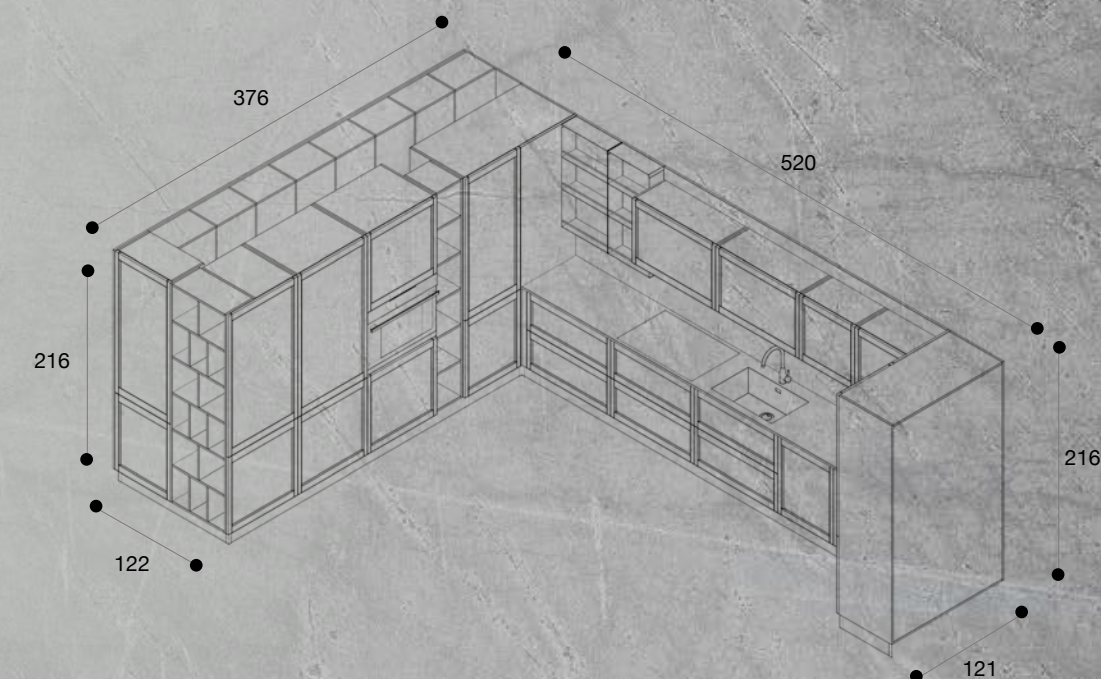

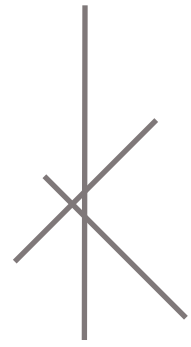

KYOTO É BELLEZZA,  
É ESPRESSIONE NATURALE  
NELLO SPAZIO QUOTIDIANO  
IN CUI I VOLUMI E LA LORO  
CAPACITÀ CONTENITIVA DIVENTA  
UN PLUS, LO SI EVINCE DALLA  
SFILATA DI PENSILI CHE SI AVVALE  
DELLA PROFONDITÀ DELLE COLONNE  
PER OTTIMIZZARE CON MAESTRIA  
OGNI VANO ANCHE IN ALTEZZA.

KYOTO IS BEAUTY, IT IS A NATURAL  
EXPRESSION IN EVERYDAY SPACE  
WHERE VOLUMES AND STORAGE  
CAPACITY ARE A PLUS.  
WALL UNITS AS DEEP AS THE  
TALL UNITS TO SKILFULLY OPTIMIZE  
EVERY SPACE, EVEN IN HEIGHT.





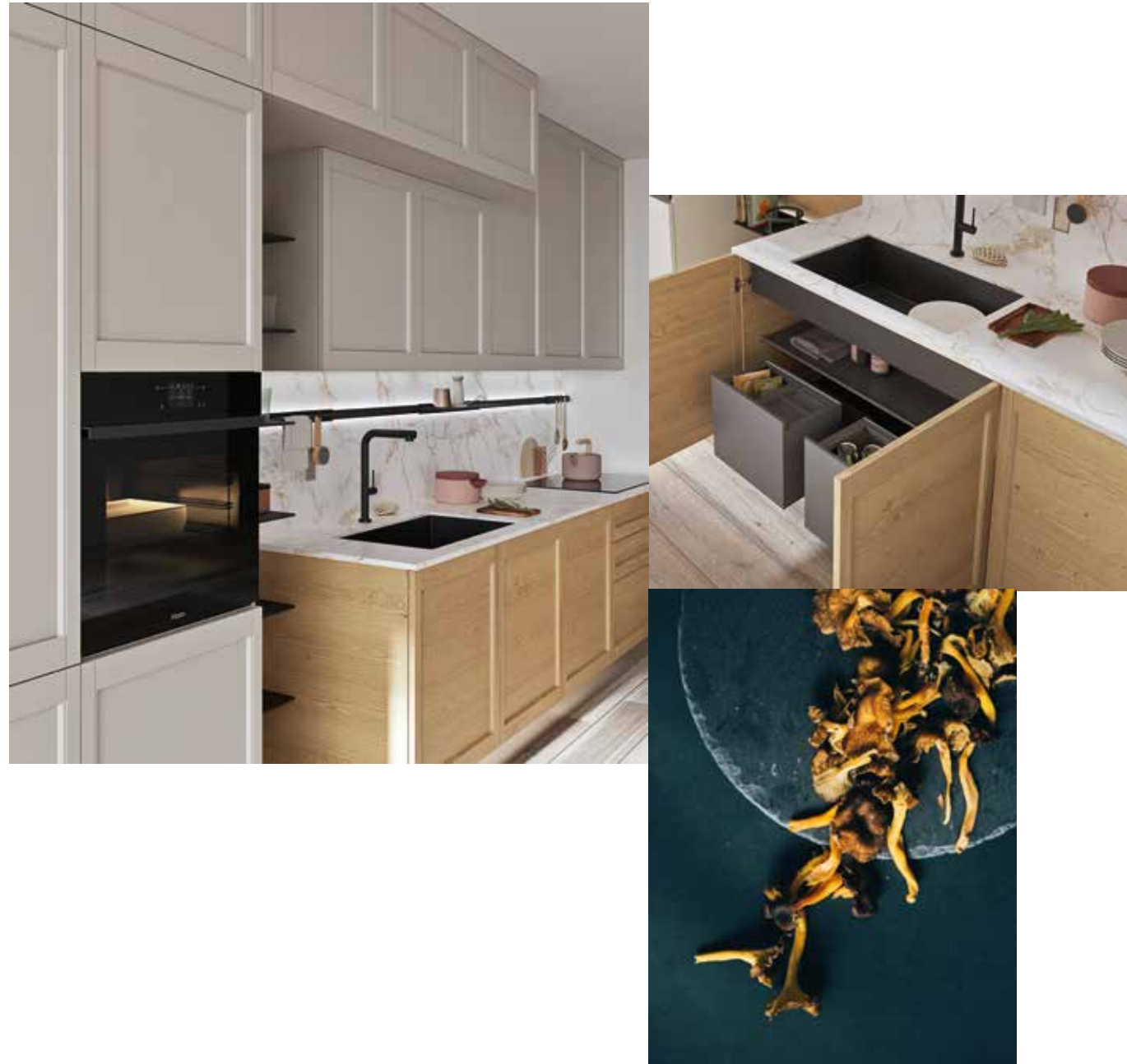
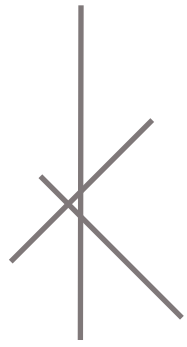

A CREARE UN INTERVALLO VISIVO BELLO E UTILE, LA BOISERIE ATTREZZATA A MENSOLE IN METALLO ILLUMINATE A LED. ALLE BASI COMODI GESTONI ESTRAIBILI AL SERVIZIO DELLA BUONA CUCINA NELLE OPERAZIONI DI RIORDINO E PULIZIA.

BOISERIE EQUIPPED WITH LED-LIT METAL SHELVES TO CREATE AN ELEGANT AND USEFUL VISUAL INTERVAL. UNDER THE SINK, CONVENIENT PULL-OUT BASKETS THAT MAKE TIDYING UP AND CLEANING EASIER.



# KYOTO / 04 FINISHES

AR-DUE THE KITCHEN

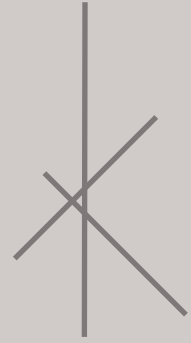

IL LACCATO OPACO GRIGIO SETA E IL ROVERE VESTONO QUESTA PROPOSTA D'ARREDO CON SOBRIA ELEGANZA, SPIRITO E MATERIA IN SINTONIA PER CREARE AMBIENTI DEDICATI A CHI METTE AL PRIMO POSTO BENESSERE E OSPITALITÀ. \_\_\_\_\_ GRIGIO SETA LACQUER AND ROVERE DRESS THIS FURNISHING PROPOSAL WITH SOBER ELEGANCE. SPIRIT AND MATERIAL IN HARMONY TO CREATE ENVIRONMENTS DEDICATED TO THOSE WHO PUT WELL-BEING AND HOSPITALITY FIRST.

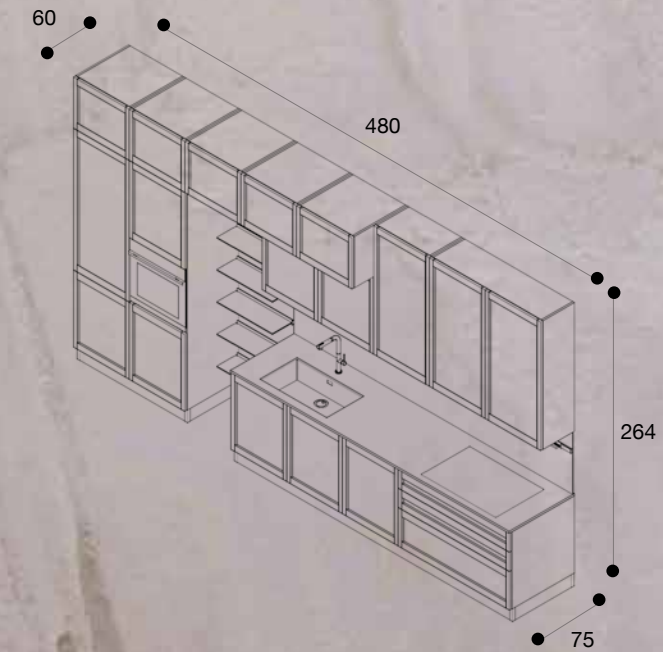

## ANTE / DOORS

01\_\_ROVERE

02\_\_LACCATO OPACO GRIGIO SETA

## PIANI / TOPS

03\_\_CERAMICA ENTZO ULTRA SATINATO

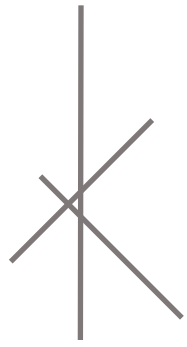

KYOTO QUI PRESENTA UN PROGETTO AD ANGOLO IN LACCATO OPACO BIANCO GHIACCIO E ROVERE NEL QUALE LE BASI RIBASSATE CONSENTONO LO SVILUPPO ARMONICO DEL TAVOLO PER DUE, CON STRUTTURA IN METALLO VERNICIATO CHAMPAGNE. LA BOISERIE IN METALLO ATTREZZATA A RIPIANI SI COORDINA PER CROMIA E MATERIALE OFFRENDOSI ALLA VISTA, CON PORTA BICCHIERI E "MINI" GIARDINO ZEN VERTICALE.

KYOTO IS PRESENTED HERE IN A CORNER COMPOSITION IN BIANCO GHIACCIO MATT LACQUER AND ROVERE WITH LOW BASE UNITS THAT ALLOW THE INSERTION OF THE TABLE WITH METAL STRUCTURE PAINTED IN CHAMPAGNE COLOUR. THE METAL BOISERIE, EQUIPPED WITH SHELVES, GLASS HOLDERS AND A MINI VERTICAL ZEN GARDEN, COORDINATES IN COLOUR AND MATERIAL.

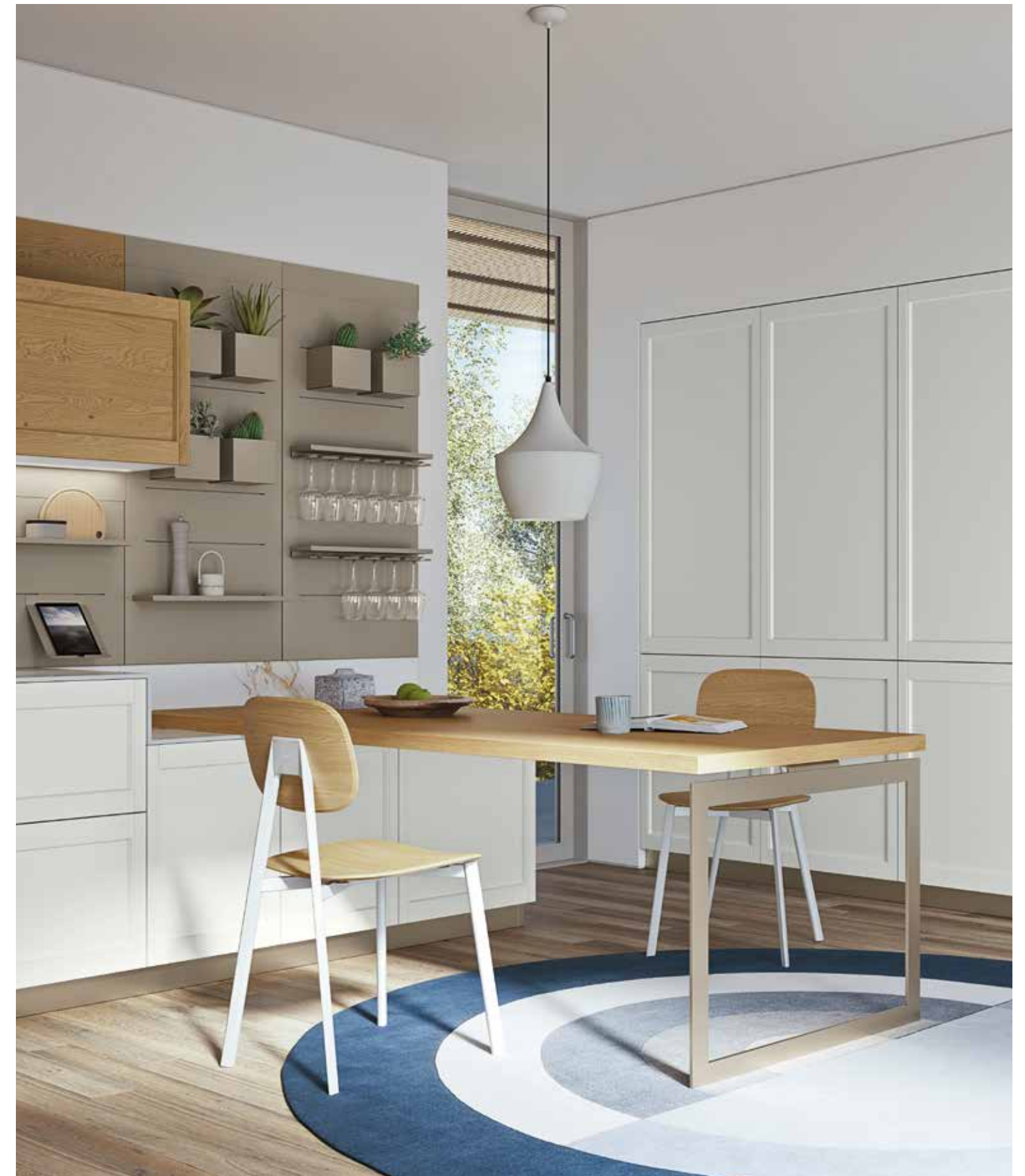



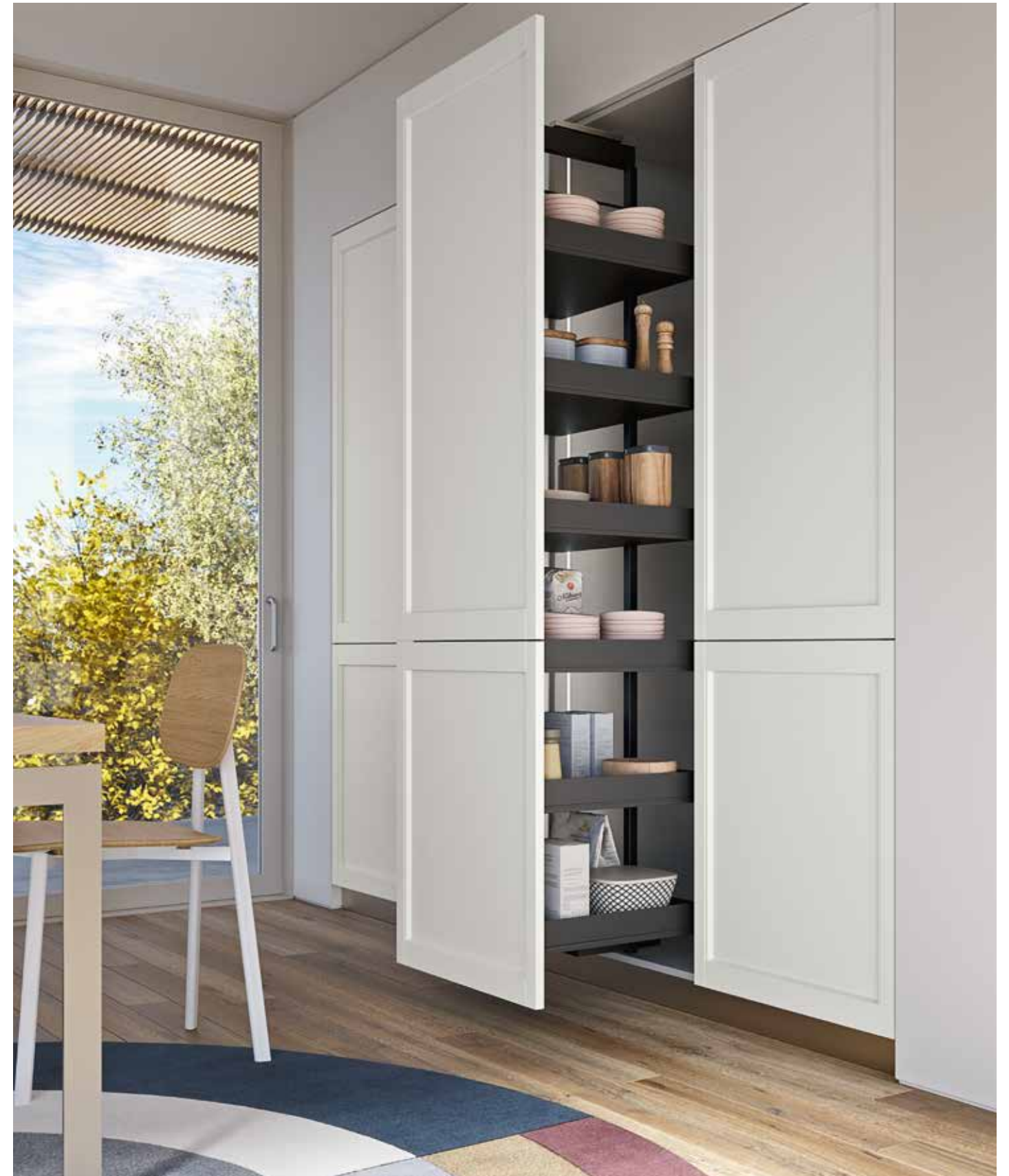

KYOTO DISPONE DI ELEMENTI A COLONNA ATTREZZATI A RIPIANI ESTRAIBILI, GRANDI SPAZI ORGANIZZATI PER PRATICARE LA "BUONA CUCINA" NELLA QUALE SERVONO INGREDIENTI DI ALTA QUALITÀ E FANTASIA, COSÌ CI PIACE PROGETTARE LA CUCINA, UN PERFETTO EQUILIBRIO TRA TUTTI GLI ELEMENTI.

KYOTO HAS TALL UNITS EQUIPPED WITH PULL-OUT SHELVES, ORGANIZED SPACES TO PRACTICE "GOOD COOKING" BY COMBINING HIGH-QUALITY INGREDIENTS AND IMAGINATION. THIS IS HOW WE LIKE TO DESIGN THE KITCHEN, A PERFECT BALANCE OF ALL ELEMENTS.



# KYOTO / 05 FINISHES

AR-DUE THE KITCHEN

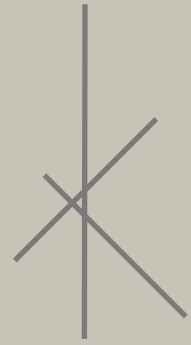

## ANTE / DOORS

- 01\_\_LACCATO OPACO BIANCO GHIACCIO
- 02\_\_ROVERE

## PIANI / TOPS

- 03\_\_CERAMICA ENTZO ULTRA SATINATO

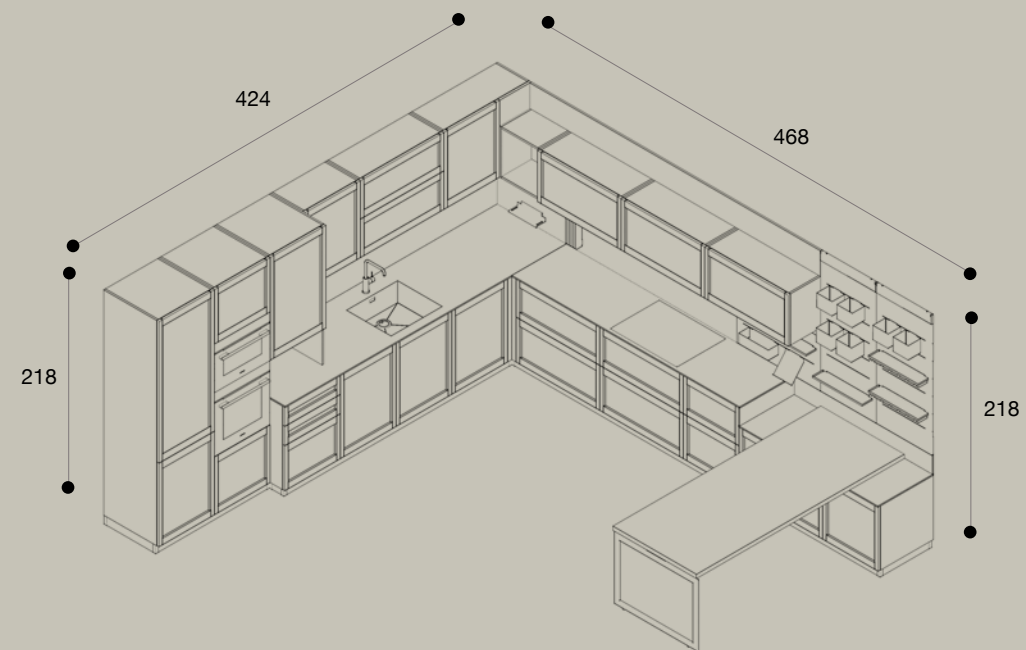

IL BIANCO DELLE ANTE A TELAIO DI KYOTO DOMINANO IL PROGETTO SCEGLIENDO LA MATERICITÀ OFFERTA DALLE VENATURE DEL ROVERE PER PENSILI E TAVOLO. AL TOP ANCORA NATURA IN PRIMO PIANO CON "ENTZO ULTRA SATINATO" CHE ESTENDE LA SUA VESTE AGLI SCHIENALI CON UN EFFETTO DI CONTINUITÀ IN NUANCE CROMATICA AI FRONTALI. \_\_\_\_\_THE WHITE OF THE KYOTO FRAMED DOORS DOMINATES THE PROJECT, CHOOSING THE MATERIALITY OF THE ROVERE GRAIN FOR THE WALL UNITS AND TABLE. NATURE IN THE FOREGROUND FOR THE TOP IN "ENTZO ULTRA SATINATO" THAT EXTENDS ITS DRESS TO THE BACKSPASHES, CREATING AN EFFECT OF CHROMATIC CONTINUITY WITH THE FRONTS.



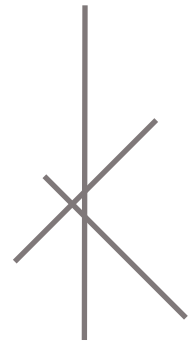

L'ISOLA CENTRALE DI KYOTO È SERVITA DA UNA PARETE DAI GRANDI VOLUMI ORGANIZZATI AL CONTENIMENTO. ORIGINALE SOLUZIONE CHE UTILIZZA IL "PASSAGGIO" CON INTELLIGENZA OPERATIVA. UNA "CABINA" DEDICATA ALLA DISPENSA A GIORNO, UNA VALIDA ALTERNATIVA A PENSILI E BASI DOVE TUTTO È IN VISTA.

THE CENTRAL ISLAND OF KYOTO IS SERVED BY A WALL WITH LARGE VOLUMES ORGANIZED FOR STORAGE. ORIGINAL IS THE SOLUTION THAT INTELLIGENTLY USES THE PASSAGE INTO THE PANTRY ROOM WHERE EVERYTHING IS IN SIGHT. A VALID ALTERNATIVE TO WALL AND BASE UNITS.







L'ISOLA "MULTIFUNZIONE" ARRICCHISCE IL PIANO COTTURA ATTRAVERSO CREATIVI ACCESSORI PORTASPEZIE IN METALLO. LA DISPENSA SI FA TEATRO DI UNO SPETTACOLARE ROVERE DELLA BOISERIE A PARETE ORGANIZZATA A GIORNO ATTRAVERSO LA STRUTTURA METALLICA A RIPIANI IN ROVERE. OGNI ELEMENTO RICHIAMA ALLA COERENZA TRA STILE E FUNZIONE.

THE MULTIFUNCTIONAL ISLAND HAS METAL SPICE RACK ACCESSORIES THAT RECALL THE OPEN STRUCTURES INSIDE THE PANTRY ROOM, WHERE THE ROVERE-COVERED WALLS STAND OUT, A CONSISTENT BALANCE BETWEEN STYLE AND FUNCTIONALITY.





UN PIANO IN ROVERE POGGIA SULLA LEGGERA STRUTTURA METALLICA INTEGRANDOSI ALL'ISOLA COME TAVOLO INFORMALE, AL CENTRO STANZA. UNA CUCINA APERTA A VISUALI "INUSUALI".

A TOP IN ROVERE RESTS ON THE LIGHT METAL STRUCTURE, INTEGRATING WITH THE ISLAND AS AN INFORMAL TABLE. AN OPEN KITCHEN WITH "UNUSUAL" VIEWS.



# KYOTO / 06 FINISHES

AR-DUE THE KITCHEN

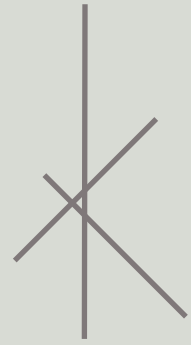

## ANTE / DOORS

- 01\_\_ROVERE
- 02\_\_Q01\_GRAFFIATO CREAM

## PIANI / TOPS

- 03\_\_STRATIFICATO HPL STATUARIO

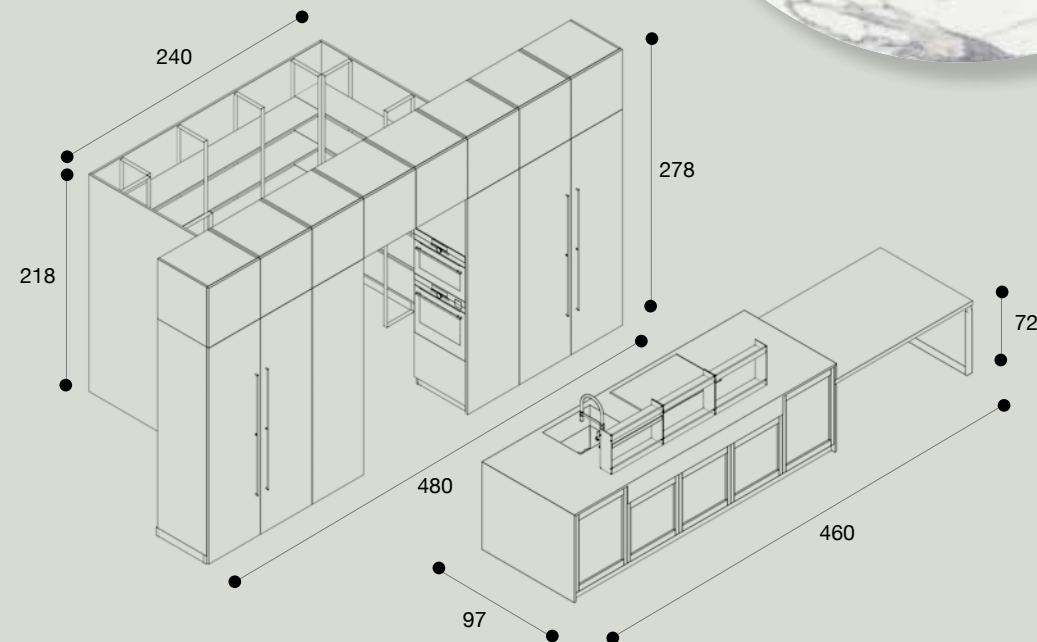

NULLA È A CASO QUANDO IL PROGETTO È PENSATO CON COERENZA E INTELLIGENZA COME PER IL GRAFFIATO CREAM CHE RIVESTE I FRONTALI DELLE COLONNE CHE DIVENTA TUTT'UNO CON L'ARCHITETTURA, IL MOBILE QUI È VOLUTAMENTE MIMETICO PER ESALTARE IL ROVERE DELL'ISOLA E UN SONTUOSO HPL STRATIFICATO STATUARIO DEL PIANO CHE LA AVVOLGE. \_\_\_\_\_ NOTHING IS CASUAL WHEN THE PROJECT IS DESIGNED WITH COHERENCE AND INTELLIGENCE, SUCH AS THE CHOICE OF THE GRAFFIATO CREAM FINISH FOR THE TALL UNITS THAT BECOME ONE WITH THE ARCHITECTURE. THE COLOR IS INTENTIONALLY NEUTRAL TO HIGHLIGHT THE ROVERE OF THE ISLAND AND A SUMPTUOUS WORKTOP IN COMPACT GRADE HPL LAMINATE STATUARIO THAT WRAPS IT.



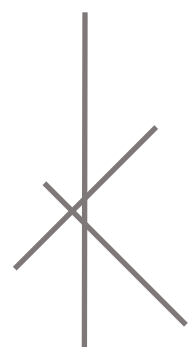

L'ANTA A TELAIO KYOTO SI PRESENTA COME UNA CORNICE "MINIMAL", ESSENZIALE NEL SUO DESIGN PERFETTA PER INTEGRARSI AD ANTE LISCE E AI COLORI PASTELLO CHE ACCOMPAGNANO LA COLLEZIONE CON NUANCE DELICATE E CONTEMPORANEE.

THE KYOTO FRAMED DOOR PRESENTS ITSELF AS A "MINIMAL" FRAME, ESSENTIAL IN ITS DESIGN, PERFECT FOR COMBINING WITH SMOOTH DOORS AND PASTEL COLORS THAT ACCOMPANY THE COLLECTION WITH DELICATE AND CONTEMPORARY NUANCES.





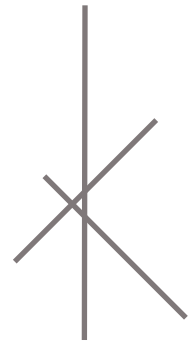

IL VERDE "CELADON" PROFUMA DI MENTA, IL COLORE SCELTO PER ESALTARE LA NATURALITÀ DI KYOTO NELL'ACCOSTAMENTO AL ROVERE DI BASI E PENSILI, TUTTO QUI PARLA DI BENESSERE E ACCOGLIENZA. IL TOP BIANCO IN QUARZORESINA SI ESTENDE AGLI SCHIENALI CONFERENDO LUMINOSITÀ E RAFFINATEZZA.

THE COLOUR VERDE CELADON SMELLS OF MINT, THIS IS THE COLOUR CHOSEN TO ENHANCE THE NATURALNESS OF KYOTO IN COMBINATION WITH THE ROVERE OF BASE AND WALL UNITS. EVERYTHING HERE SPEAKS OF WELL-BEING AND HOSPITALITY. THE WHITE OF THE QUARZORESINA WORKTOP EXTENDS TO BACKSPLASHES GIVING BRIGHTNESS AND REFINEMENT.



# KYOTO / 07 FINISHES

AR-DUE THE KITCHEN

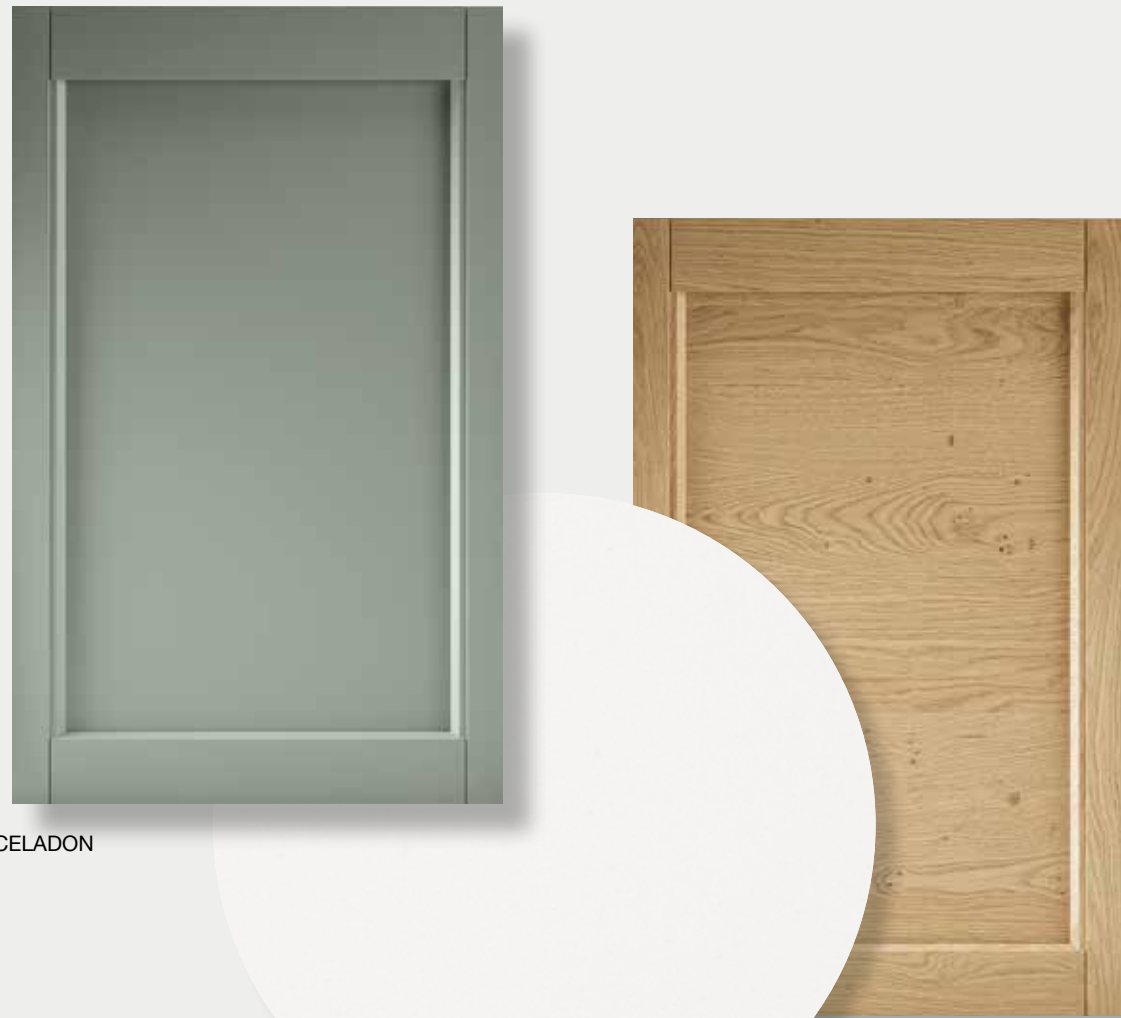
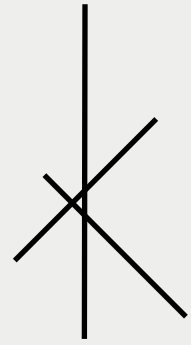

## ANTE / DOORS

01\_\_LACCATO OPACO VERDE CELADON

02\_\_ROVERE

## PIANI / TOPS

03\_\_QUARZORESINA VEGA ULTRA BIANCO

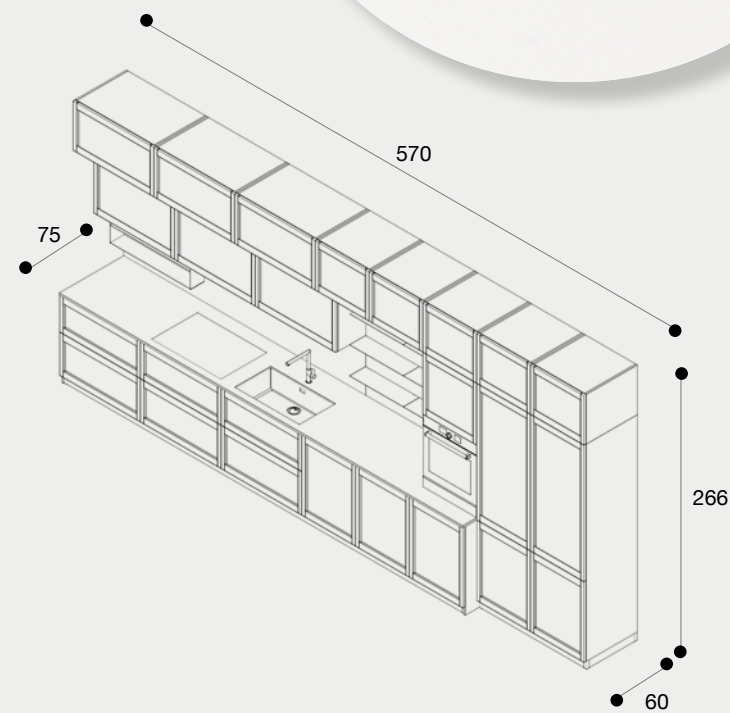

IL VERDE È IL COLORE ASSOCIATO AL CHAKRA DEL CUORE, EVOCA EQUILIBRIO MA A LIVELLO PERCETTIVO EMANA VIBRAZIONI DI SERENITÀ E CURA, QUELLA STESSA CURA NECESSARIA QUANDO SI PROGETTA UN AMBIENTE CUCINA. L'EQUILIBRIO TRA IL ROVERE E IL BIANCO DEI PIANI IN QUARZORESINA VEGA ULTRA BIANCO, IN KYOTO SI RESPIRA IL RITMO DELLA VITA. \_\_\_\_\_GREEN IS THE COLOR ASSOCIATED WITH THE HEART CHAKRA, IT EVOKES HARMONY BUT, ON A PERCEPTIVE LEVEL IT GIVES OFF VIBRATIONS OF SERENITY AND CARE. THE SAME CARE REQUIRED IN DESIGN OF A KITCHEN WHICH, IN THIS COMPOSITION, IS EXPRESSED IN THE BALANCE BETWEEN THE ROVERE AND THE WHITE OF THE WORKTOPS IN QUARZORESINA VEGA. KYOTO MAKES YOU BREATHE THE RHYTHM OF LIFE.

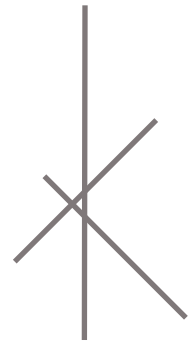

KYOTO, IN LACCATO OPACO NEBBIA E ROVERE SI PRESTA AD INTERPRETARE CASE E APPARTAMENTI DOVE L'ESSENZIALITÀ FA RIMA CON CREATIVITÀ. LA PENISOLA A BASE RIBASSATA, SI FA TAVOLA D'ARTISTA PER CHI CON LE MANI SI PREPARA AD INVENTARE NUOVI PIATTI.

KYOTO, IN MATT NEBBIA LACQUER AND ROVERE, IS SUITABLE FOR INTERPRETING HOMES WHERE ESSENTIALITY RHYMES WITH CREATIVITY. THE PENINSULA WITH LOW BASE UNITS BECOMES AN ARTIST'S TABLE FOR THOSE PREPARING TO INVENT NEW PLATES.





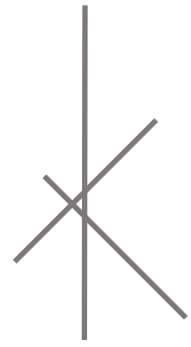

LA COLONNA CENTRALE IN LACCATO OPACO NEBBIA DEDICATA AGLI ELETTRODOMESTICI CREA UN'INTERESSANTE SIMMETRIA NELLA PARETE DAI FRONTALI IN ROVERE, MENTRE LO SVILUPPO A PENISOLA OFFRE UN "PIANO" IDEALE PER COLAZIONI O PRANZO PER DUE, CON VISTA.

THE CENTRAL TALL UNITS IN MATT NEBBIA LACQUER, DEDICATED TO APPLIANCES, CREATE AN INTERESTING SYMMETRY IN THE WALL WITH ROVERE FRONTS, WHILE THE PENINSULA DEVELOPMENT OFFERS AN IDEAL PLACE FOR BREAKFAST OR LUNCH.



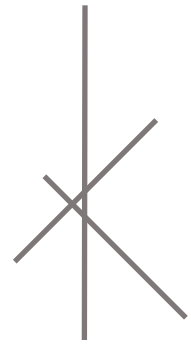

KYOTO DISPONE DI AMPI SPAZI ORGANIZZATI ALL'INTERNO DI BASI E COLONNE CHE EVIDENZIANO QUANTO L'EFFICIENZA DIVENTI UN PLUS INDISPENSABILE A FARE DI UN PROGETTO LA SUA RIUSCITA.

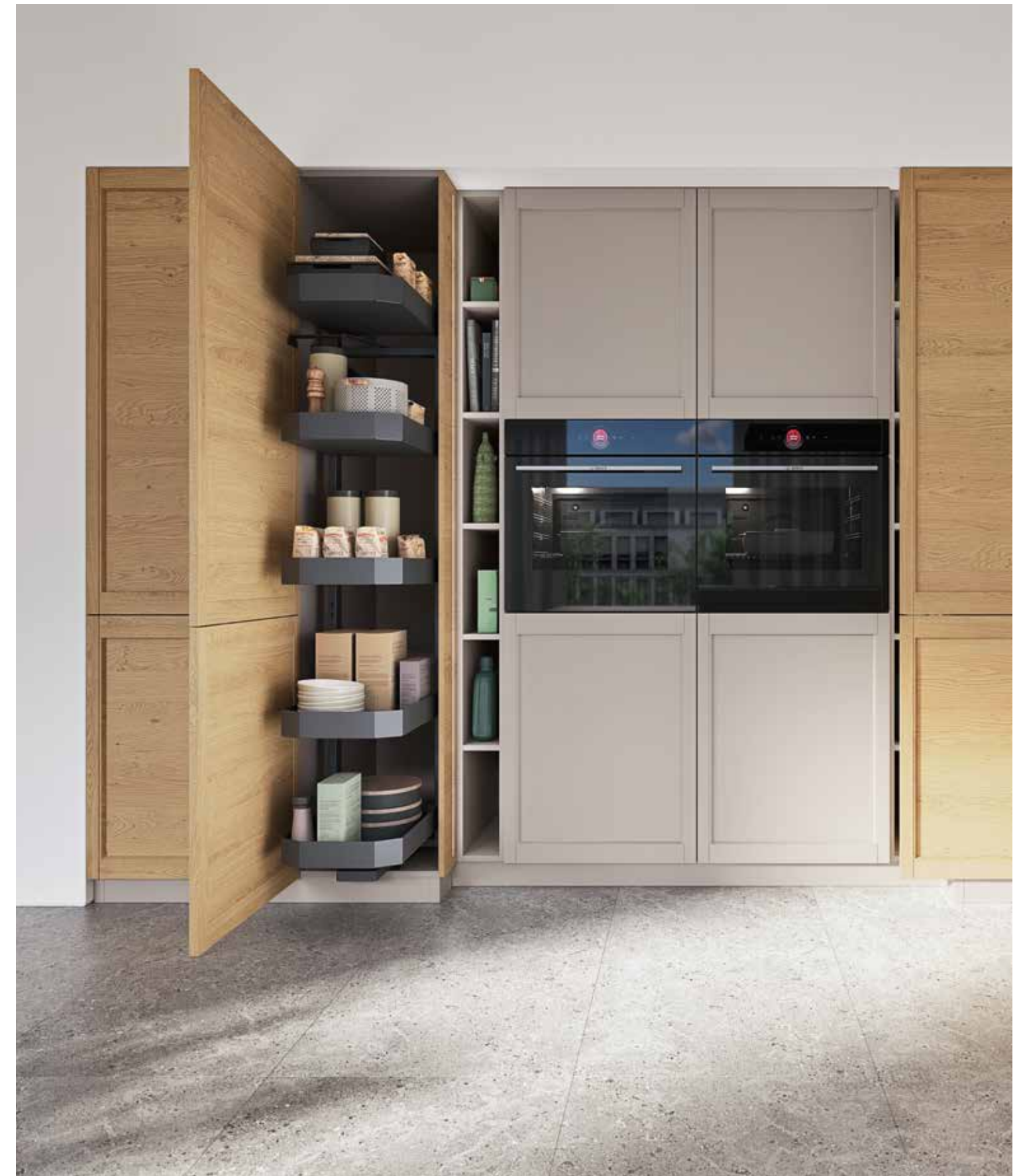

KYOTO HAS BASE UNITS AND TALL UNITS WITH ORGANIZED SPACES THAT HIGHLIGHT HOW EFFICIENCY BECOMES AN INDISPENSABLE PLUS.

# KYOTO / 08 FINISHES

AR-DUE THE KITCHEN

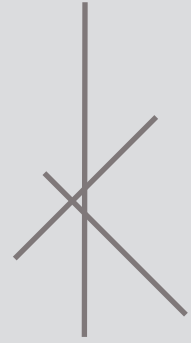

## ANTE / DOORS

01\_\_ROVERE

02\_\_LACCATO OPACO NEBBIA

## PIANI / TOPS

03\_\_CERAMICA ELEGANCE WHITE LUCIDO

LE ANTE A TELAIO IN ROVERE E LACCATO OPACO NEBBIA ESALTANO LA DELICATEZZA E LA SOBRIETÀ ESTETICA DI UN PROGETTO CHE SI COMPLETA NEI PIANI E SCHIENALI DI UN ELEGANCE WHITE LUCIDO CHE RISPECCHIA UNA SCELTA DI EQUILIBRIO.  
\_\_\_\_FRAMED DOORS IN ROVERE AND MATT NEBBIA LACQUER ENHANCE THE DELICACY AND AESTHETIC SOBRIETY OF A PROJECT THAT IS COMPLETED BY THE WORKTOPS AND BACKSPLASHES IN ELEGANCE WHITE LUCIDO.

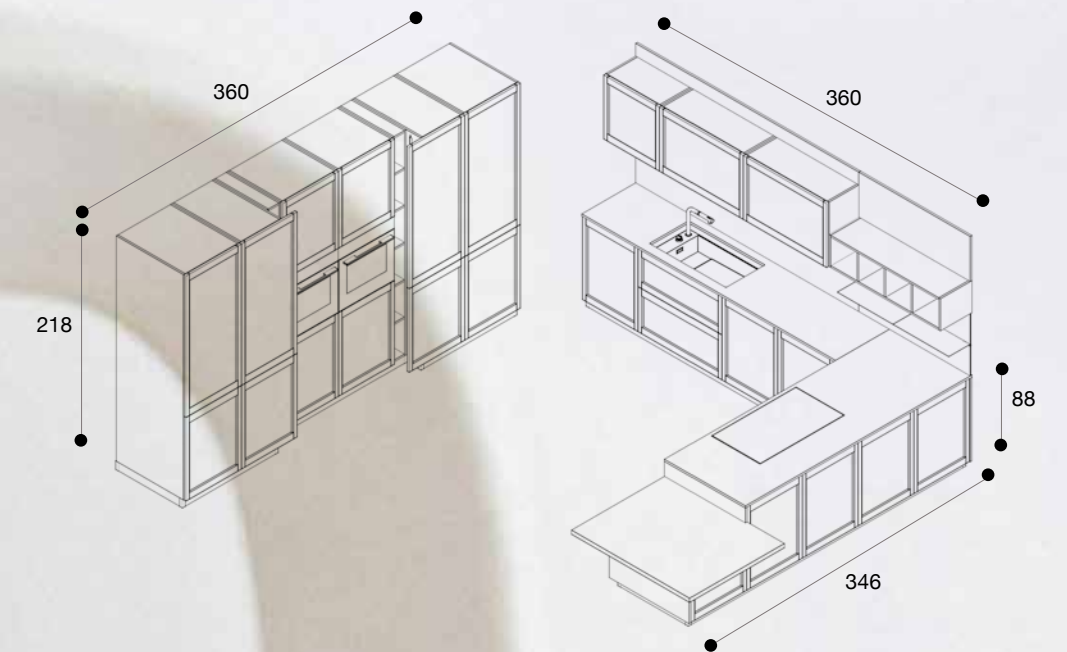

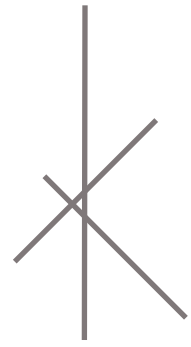

SUPERFICI LISCE E A TELAIO SI INTEGRANO CON MAESTRIA PER COMPORRE PROGETTI CUCINA VERSATILE E ARMONIOSI, SPAZI APERTI ALLE POSSIBILITÀ E A NUOVI ORIZZONTI CREATIVI. QUI L'ISOLA CENTRALE OFFRE UN'INCANTEVOLE RISTORO, VESTITO DI STRATIFICATO HPL PULPIS DARK.

SMOOTH AND FRAMED DOORS ARE SKILLFULLY INTEGRATED IN THE COMPOSITION OF VERSATILE AND HARMONIOUS KITCHEN DESIGNS, SPACES OPEN TO NEW CREATIVE HORIZONS. THE CENTRAL ISLAND OFFERS AN ENCHANTING BREAKFAST BAR COVERED WITH PULPIS DARK COMPACT GRADE HPL LAMINATE.







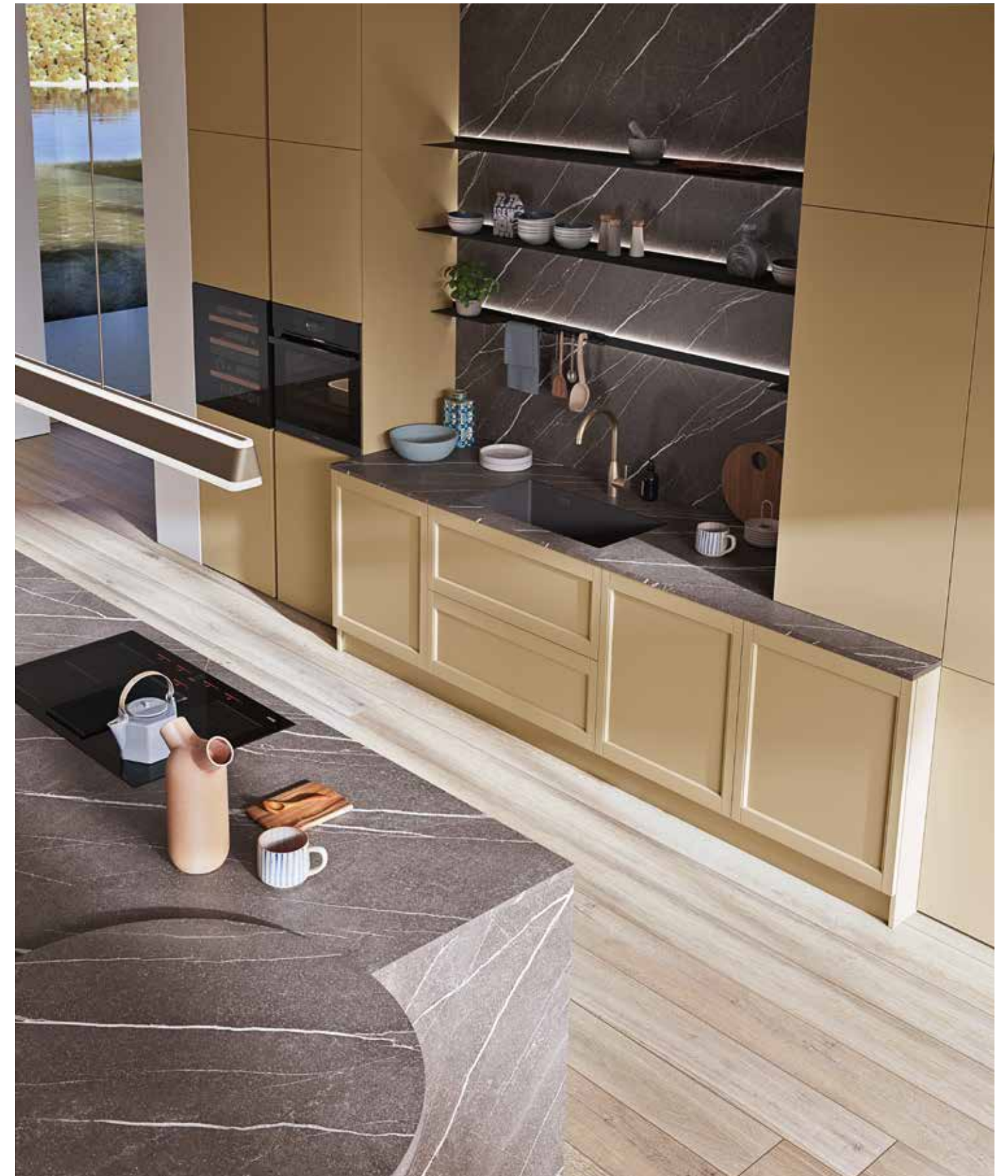

SE L'ASPETTO ESTETICO DELLA CUCINA È LA SCINTILLA CHE ACCENDE L'INTERESSE, LA SUA STRUTTURA CAPIENTE E ORGANIZZATA È IL MOTORE PER RENDERE I GESTI QUOTIDIANI DI RIORDINO E PULIZIA SNELLI ED EFFICACI. NEL DETTAGLIO, CESTONI RACCOLTA DIFFERENZIATA CON GUIDE BLUMOTION.

IF THE AESTHETICS OF THE KITCHEN IS THE SPARK THAT LIGHTS UP INTEREST, ITS DRIVING FORCE IS THE CAPACITY AND ORGANIZED STRUCTURE THAT MAKE THE DAILY GESTURES OF TIDYING AND CLEANING FAST AND EFFECTIVE. IN THE DETAIL, UNDER-SINK DRAWER WITH BLUMOTION RUNNERS EQUIPPED WITH BINS FOR SEPARATE WASTE COLLECTION.



# KYOTO / 09 FINISHES

AR-DUE THE KITCHEN

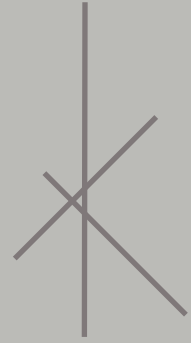

## ANTE / DOORS

- 01\_\_LACCATO OPACO MALTO GOLD
- 02\_\_LACCATO OPACO QØ1 MALTO GOLD

## PIANI / TOPS

- 03\_\_STRATIFICATO HPL PULPIS DARK

LA MODERNITÀ RICHIEDE EFFICIENZA, SENZA RINUNCIARE AL BELLO, ALLA PREZIOSITÀ DELLA MATERIA E ALLA CURA DEL DETTAGLIO. ANTA LISCIA E ANTA A TELAIO IN LACCATO SI ALTERNANO AL TOP E SCHIENALI IN HPL STRATIFICATO PULPIS DARK A CONTRASTO.

MODERNITY REQUIRES EFFICIENCY WITHOUT GIVING UP ON BEAUTY, PRECIOUSNESS OF MATERIALS AND ATTENTION TO DETAIL. SMOOTH DOORS AND FRAMED DOORS ALTERNATE WITH CONTRASTING WORKTOPS AND BACKSPLASHES IN PULPIS DARK COMPACT GRADE HPL LAMINATE.

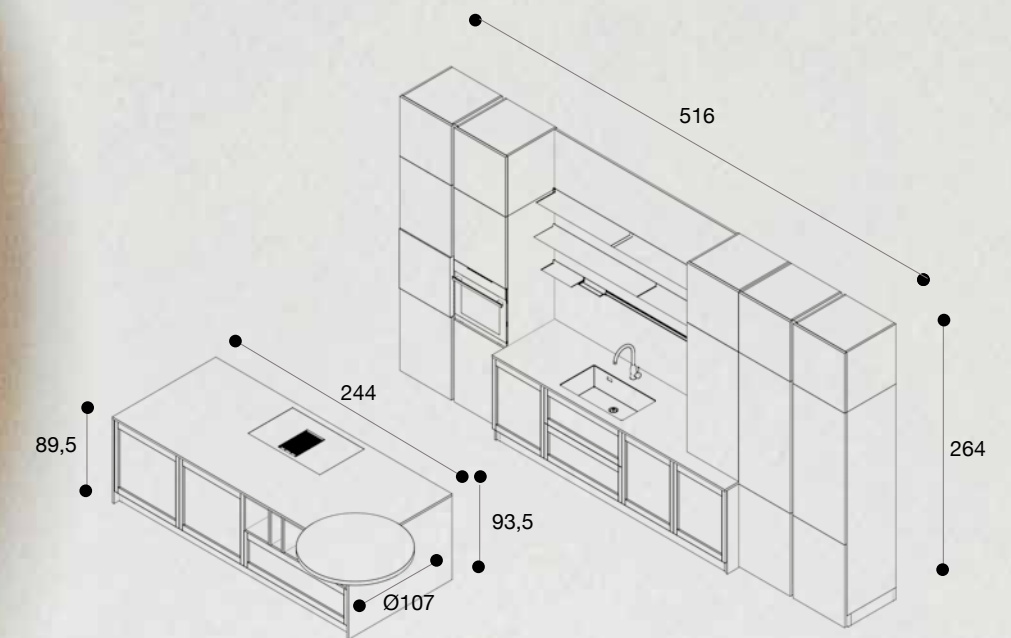

FINITURE  
KYOTO ROVERE  
E LACCATO OPACO  
/  
FINISHES  
KYOTO ROVERE  
AND MATT  
LACQUERED

AR-DUE THE KITCHEN

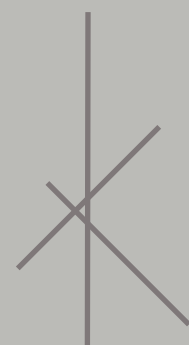

ANTA KYOTO  
ROVERE



ANTA KYOTO  
LACCATO OPACO

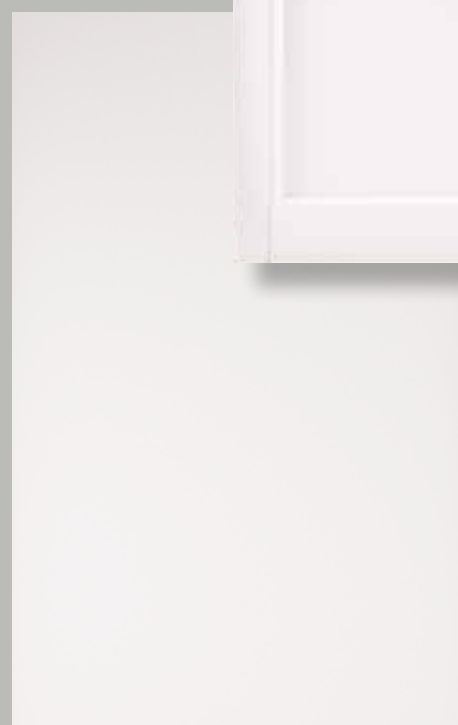

ANTA Q01  
LACCATO LISCIO

IL PROGETTO KYOTO  
OFFRE LA POSSIBILITÀ  
DI ABBINARE ALL'ANTA TELAIO,  
ANTE LISCE Q01, SCEGLIENDO  
TRA OLTRE 70 FINITURE DAI PET  
E LACCATI OPACHI E LUCIDI  
O EFFETTO LEGNO, RESINA,  
CEMENTO E FENIX.  
INOLTRE, I COLORI DEI LACCATI  
SONO PERSONALIZZABILI,  
SU RICHIESTA, ATTRAVERSO  
LA SCALA RAL O NCS.  
KYOTO, UN PROGRAMMA  
COMPLETO CHE APRE AD INFINITE  
INCLINAZIONI DI GUSTO.

THE FRAMED DOOR OF THE KYOTO  
COLLECTION CAN BE PAIRED WITH THE  
SMOOTH DOOR OF THE Q01 MODEL  
IN ITS VARIED OFFER OF COLOURS IN PET,  
FENIX, MELAMINE WOOD-EFFECT,  
RESIN, CEMENT OR MATT COLOURS.  
OR, IN MATT AND GLOSSY LACQUERED  
COLOURS ALSO CUSTOMIZABLE  
ACCORDING TO RAL OR NCS CHART.  
KYOTO, A COMPLETE PROGRAM  
THAT OPENS UP TO INFINITE  
INTERPRETATIONS OF STYLE.



KYOTO E Q01:  
LACCATO OPACO BIANCO GHIACCIO



KYOTO E Q01:  
LACCATO OPACO GRIGIO SETA



KYOTO E Q01:  
LACCATO OPACO NEBBIA

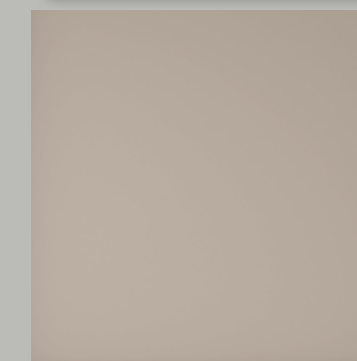
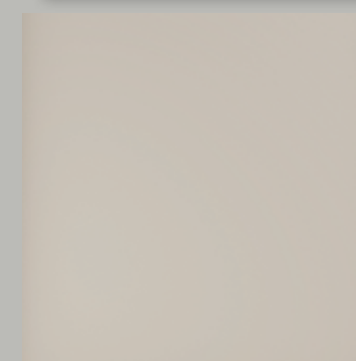
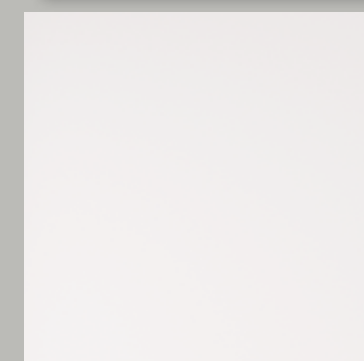

KYOTO E Q01:  
LACCATO OPACO MALTO GOLD



KYOTO E Q01:  
LACCATO OPACO ROSA JADORE



KYOTO E Q01:  
LACCATO OPACO VERDE CELADON

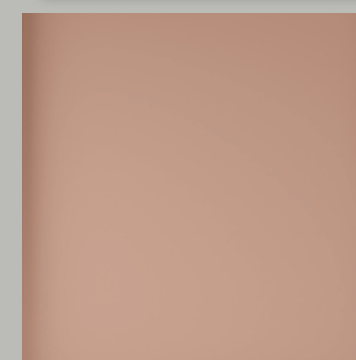

# KYOTO / INDEX

AR-DUE THE KITCHEN

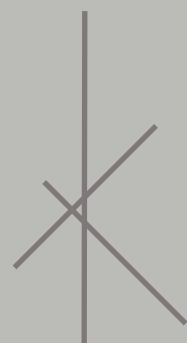

RAFFINATO GUSTO CLASSICO E STILE MODERNO SI INCONTRANO E SI FONDONO PERFETTAMENTE TRA LORO. \_\_\_\_\_REFINED CLASSIC TASTE AND MODERN STYLE MEET AND BLEND PERFECTLY WITH EACH OTHER.



**KYOTO / 05 PAGES\_\_ 42-51**

01\_\_LACCATO OPACO BIANCO GHIACCIO  
02\_\_ROVERE



**KYOTO / 06 PAGES\_\_ 52-63**

01\_\_ROVERE  
02\_\_Q01\_GRAFFIATO CREAM



**KYOTO / 01 PAGES\_\_ 06-15**

01\_\_LACCATO OPACO NEBBIA  
02\_\_ROVERE



**KYOTO / 02 PAGES\_\_ 16-23**

01\_\_LACCATO OPACO ROSA JADORE  
02\_\_LACCATO OPACO Q01 ROSA JADORE



**KYOTO / 07 PAGES\_\_ 64-71**

01\_\_LACCATO OPACO VERDE CELADON  
02\_\_ROVERE



**KYOTO / 08 PAGES\_\_ 72-81**

01\_\_ROVERE  
02\_\_LACCATO OPACO NEBBIA



**KYOTO / 03 PAGES\_\_ 24-33**

01\_\_LACCATO OPACO BIANCO GHIACCIO  
02\_\_LACCATO OPACO VERDE CELADON



**KYOTO / 04 PAGES\_\_ 34-41**

01\_\_ROVERE  
02\_\_LACCATO OPACO GRIGIO SETA



**KYOTO / 09 PAGES\_\_ 82-93**

01\_\_LACCATO OPACO MALTO GOLD  
02\_\_LACCATO OPACO Q01 MALTO GOLD





**AR-DUE S.p.A.**

33080 Ghirano di Prata (PN) Italy  
Via Palazzetto,56

Tel. +39 0434 626740  
Fax +39 0434 626774

[ar-due@ar-due.it](mailto:ar-due@ar-due.it)  
[www.ar-due.it](http://www.ar-due.it)